



## Investigation of impact energy absorption of AA6061 and its composites: role of post-aging cooling methods

G. V. Krishna Reddy

*Department of Mechanical Engineering, Government Polytechnic, Channasandra, Bangalore, Karnataka, India.*  
krishnareddy.gpc@gmail.com

B. K. Naveen Kumar

*Department of Mechanical Engineering, M S Ramaiah Institute of Technology, Bengaluru, Karnataka, India.*  
*Department of Mechanical Engineering, National Institute of Technology Karnataka, Surathkal, Karnataka, India.*  
naveenkumarbk2013@gmail.com; <https://orcid.org/0000-0002-3774-4551>

G. Hareesha\*

*Department of Mechanical Engineering, Government Engineering College, HuvinaHadagali, Karnataka, India.*  
harishsb@gmail.com; <https://orcid.org/0000-0003-1274-9716>

A. M. Rajesh

*Department of Mechanical Engineering, S.J.M. Institute of Technology, Chitradurga, Karnataka, India.*  
rajesh.am82@gmail.com; <https://orcid.org/0000-0003-1843-239X>

Saleemsab Doddamani

*Department of Mechanical Engineering, National Institute of Technology Karnataka, Surathkal, Karnataka, India.*  
saleemsabdoddamani@gmail.com; <http://orcid.org/0000-0002-8498-1488>

**ABSTRACT.** Al6061 and its composites are widely employed in applications requiring high strength and impact resistance. Heat treatment, particularly ageing, is a well-established method for enhancing the mechanical properties of these composites. However, the influence of post-ageing cooling methods on the impact energy absorption capacity of Al6061 and its composites is not well understood. This investigation aims to examine the impact energy absorption of Al6061 and its composites after ageing at 460°C for 2 hours, employing different cooling methods, including furnace cooling, air cooling, and water cooling. The composites were produced using the stir casting technique with varying weight fractions of graphite and SiC particles based on Taguchi's design of experiments. Charpy impact tests were conducted using a specialised testing machine. The results reveal that the impact energy absorption capacity of the composites is influenced by the cooling method used after the ageing treatment. Furnace cooling demonstrated the highest impact energy absorption capacity compared to the other cooling methods, exhibiting a 28% increase relative to the monolithic aluminium alloy. Furthermore, it was observed that the impact energy absorption capacity of



**Citation:** Krishna Reddy, K. R., Naveen Kumar, B. K., Hareesha, G., Rajesh, A. M., Doddamani, S., Investigation of impact energy absorption of AA6061 and its composites: role of post-aging cooling methods, *Frattura ed Integrità Strutturale*, 66 (2023) 261-272.

**Received:** 26.07.2023

**Accepted:** 30.08.2023

**Online first:** 31.08.2023

**Published:** 01.10.2023

**Copyright:** © 2023 This is an open access article under the terms of the CC-BY 4.0, which permits unrestricted use, distribution, and reproduction in any medium, provided the original author and source are credited.



the composites did not improve with an increase in the weight fraction of SiC particles, while the addition of graphite negatively impacted the absorption capacity.

**KEYWORDS.** Metal matrix composite, Al-graphite composite, Impact energy, Al-SiC, Post-ageing cooling.

## INTRODUCTION

Al6061 and its composites are widely used in various applications that require high strength and impact resistance, such as aerospace, automotive, and structural engineering [1]. Zakaria Belabed et al. [2–4] used some advanced micromechanical models to evaluate composites' mechanical properties. The mechanical properties of Al6061 and its composites can be improved by heat treatment processes such as ageing. Consequently, the precipitation of reinforcing phases occurs within the aluminium matrix [5]. However, the cooling method applied post-ageing treatment can also influence these materials' impact on energy absorption capacity. The cooling rate can directly affect the material's microstructure and various mechanical properties [6], including the impact energy absorption capacity.

The cooling rate can significantly affect the microstructure and properties of aluminium alloys [7,8]. During the cooling process, the speed at which a material's temperature decreases influences the transformation of its microstructure, ultimately shaping its mechanical and physical characteristics [9]. Rapid cooling rates, such as water or oil quenching [10], can enhance mechanical properties by producing a fine-grained structure [11]. This results in increased mechanical strength, hardness, and improved wear resistance. The finer grains also inhibit the growth of large intermetallic particles, which can be detrimental to material properties. However, they also pose challenges such as potential distortion, cracking, or even complete failure due to residual stresses [12,13].

Conversely, slower cooling rates, like those associated with controlled furnace cooling, permit the growth of coarser microstructure (larger grains) due to the extended time available for atomic diffusion [14]. This can improve ductility, better formability, and enhanced resistance to stress corrosion cracking. However, it may also result in reduced strength [15]. Moreover, the cooling rate influences the precipitation kinetics of various alloying elements. Rapid cooling can sometimes trap solute atoms within the lattice structure, hindering the formation of certain precipitates. On the other hand, slower cooling rates allow for more controlled precipitation, contributing to improved age-hardening characteristics. The appropriate cooling rate depends on the specific alloy and the desired properties for the application [16].

In industrial practices, various post-ageing cooling methods are frequently utilised for aluminium alloys, and each process imparts unique impacts on material properties. These techniques encompass furnace cooling, characterised by controlled cooling in a controlled environment; air cooling, permitting materials to cool in the surrounding air naturally; and water quenching, involving rapid cooling through immersion in water or oil [17]. However, the effect of these cooling methods on the impact energy absorption capacity of Al6061 and its composites is not well understood. Therefore, there is a need to investigate the effect of post-ageing cooling methods on the impact energy absorption capacity of Al6061 and its composites.

The study's innovation arises through its emphasis on investigating the impact energy absorption capacity of Al6061 and its composites, particularly in terms of various post-ageing cooling (PAC) techniques. While the mechanical properties of these composites have been studied extensively regarding heat treatment and ageing, the role of cooling methods after the ageing process has not been well-explored. By conducting a systematic investigation on the impact energy absorption capacity of Al6061 and its composites under different cooling conditions (furnace cooling, air cooling, and water cooling), this study aims to fill the knowledge gap and provide insights into the effect of cooling methods on the final mechanical performance of the materials.

## MATERIALS AND METHODS

### *Materials*

The materials used in this study were Al6061 alloy, graphite particles, and SiC particles, as shown in Fig.1. The Al6061 alloy was selected as the matrix material due to its high strength, good machinability, and widespread use in various industries [18]. The graphite and SiC particles [19] were chosen as the reinforcement materials due to their high

strength, low density, and excellent thermal and electrical conductivity [20]. The chemical composition of Al6061 alloy is given in Tab. 1.

Fe	Si	Mn	Zn	Cu	Ti	Mg	Cr	Al
0.094	0.69	0.034	0.001	0.23	0.03	0.85	0.06	98.011

Table 1: Chemical Composition of Al6061 Alloy [21].

The graphite and SiC particles used in this study were 10-20  $\mu\text{m}$  and 44  $\mu\text{m}$  obtained from a commercial supplier. The weight fractions of graphite (0, 3 and 6wt%) and SiC particles (0, 3 and 6wt%) in the composites were varied using Taguchi's design of experiments.

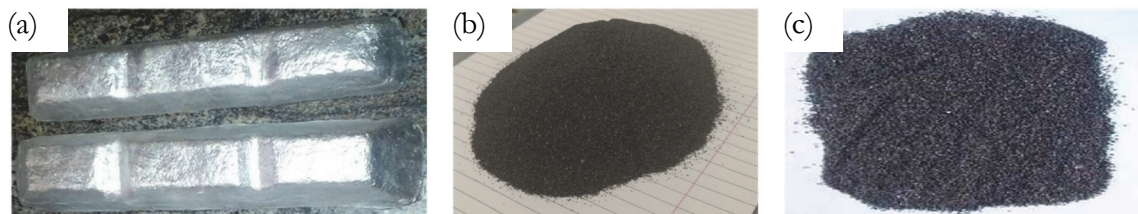

Figure 1: (a) Aluminum 6061 blocks; (b) Graphite particles; (c) Silicon Carbide particles.

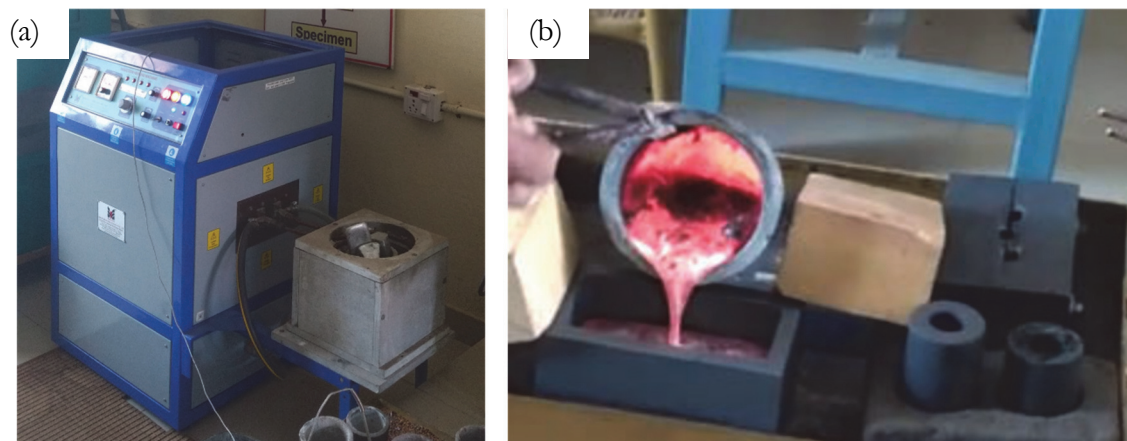

Figure 2: (a) Stir casting setup; (b) Molten composite pouring into a graphite mould.

### *Casting and specimen preparation*

Al6061-Graphite/SiC hybrid composites were prepared using stir-casting [22]. The Al6061 alloy was melted in a furnace at a temperature of 720°C. Graphite and SiC particles of different weight fractions were added to the molten aluminium and stirred using a mechanical stirrer with a stirring speed of 500 rpm for 5 minutes [19]. Hexachloroethane ( $\text{C}_2\text{Cl}_6$ ), as a gasifier, has been added to the molten aluminium to remove the gases. Impurities in the molten aluminium that is slag are also removed. The weight fractions of the reinforcements were varied according to Taguchi's design of experiments. Before pouring into the mould cover flux was added to prevent the gas from entering molten metal, as shown in Fig.2. The molten composite was poured into a preheated graphite mould because it has low reactivity with aluminium and does not stick to the molten metal. This allows for easy removal of the cast part after solidification. After the solidification of the composites, the samples were machined to the required dimensions.

Charpy V-notch specimens were machined from the as-cast Al6061-graphite/SiC hybrid composites using a wire E.D.M. machine. The specimens were prepared with dimensions of 55mm x 10mm x 10mm, following ASTM E23 standards [23].

The notch was machined on one face of the specimen using a milling machine. The notch dimensions were 2mm deep, 10mm long, and with a 45° angle. The specimens were then carefully polished to remove any surface imperfections and ensure a smooth surface finish. The specimen preparation process was carried out with great care to ensure the accuracy and repeatability of the impact test results.

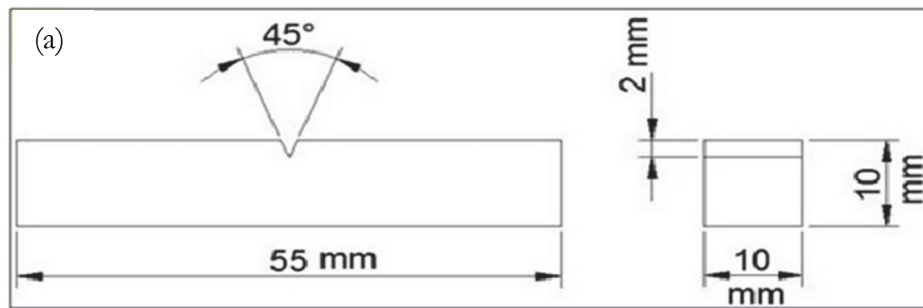

All dimensions are in mm



Figure 3: (a) Geometry and (b) Prepared Charpy V-notch specimens.

#### *Artificial aging*

The specimens were treated with heat before testing to study the impact of post-ageing cooling methods on the impact energy absorption of Al6061-graphite/SiC hybrid composites. The specimens were heated in a muffle furnace at a temperature of 460°C to promote precipitation hardening, a commonly used technique to enhance the strength and hardness of aluminium alloys [5]. The specimens were held at this temperature for 2 hours to allow complete precipitation.

After the ageing treatment, three different cooling methods were considered as a processing parameters as per Taguchi's design of experiments (DOE): (a) furnace cooling (FC), (b) air cooling (AC), and (c) water quenching (WQ). For furnace cooling, the specimens were allowed to cool naturally in the furnace. The specimens were removed from the furnace and allowed to cool in ambient air for air cooling. For water quenching, the specimens were rapidly immersed in a water bath immediately after removal from the furnace to promote rapid cooling. These cooling methods were chosen to simulate different cooling rates and conditions encountered in industrial applications.

#### *Experimentation*

The Al6061-graphite/SiC hybrid composites were prepared using the stir casting method as per Taguchi's design of experiments (DOE) for the parameters shown in Tab. 2. The impact energy absorption tests were performed on the prepared Charpy V-notch specimens using a Charpy impact testing machine [24]. The specimens were positioned with the notch facing outward, and the pendulum was released from a height of 2.75m. The impact energy absorbed by the specimen was calculated by measuring the energy difference between the initial and final positions of the pendulum.

S.N	Parameters	Level 1	Level 2	Level 3
1	Wt% of graphite	00	03	06
2	Wt% of SiC	00	03	06
3	Post-Aging Cooling (PAC) Methods	FC	AC	WQ

Table 2: Taguchi's process parameters and their levels.

## RESULTS AND DISCUSSIONS

### Microstructure

The microstructure analysis of the Al6061-graphite, Al6061-SiC particulate and Al6061-graphite/SiC composite, as shown in Fig.4, revealed a uniform distribution of the reinforcement, indicating adequate mixing during the fabrication process [19].

The mechanical stirrer used in the process overcame the surface energy barrier caused by the poor wettability of graphite by the aluminium composite. During mixing, the flow transitions and momentum transfer prevented particles from settling in the matrix and induced local hydrodynamic forces that separated the clustering of graphite particles. This led to the formation of a homogeneous microstructure throughout the cast segment.

In order to determine the chemical composition of the Al6061 and composites, EDS measurements were carried out on individual specimens. The results indicated that the silicon and magnesium content indicated these elements' presence in the Al6061 alloy (Fig.5(a)). The results indicated that the chemical composition of the composites was uniform, with a higher percentage of carbon than silicon and magnesium. This suggested the presence of graphite and SiC reinforcement in the Al6061 matrix (Fig.5(b-d)). The EDS measurements yielded important information regarding the chemical composition of both the Al6061 alloy and its composites.

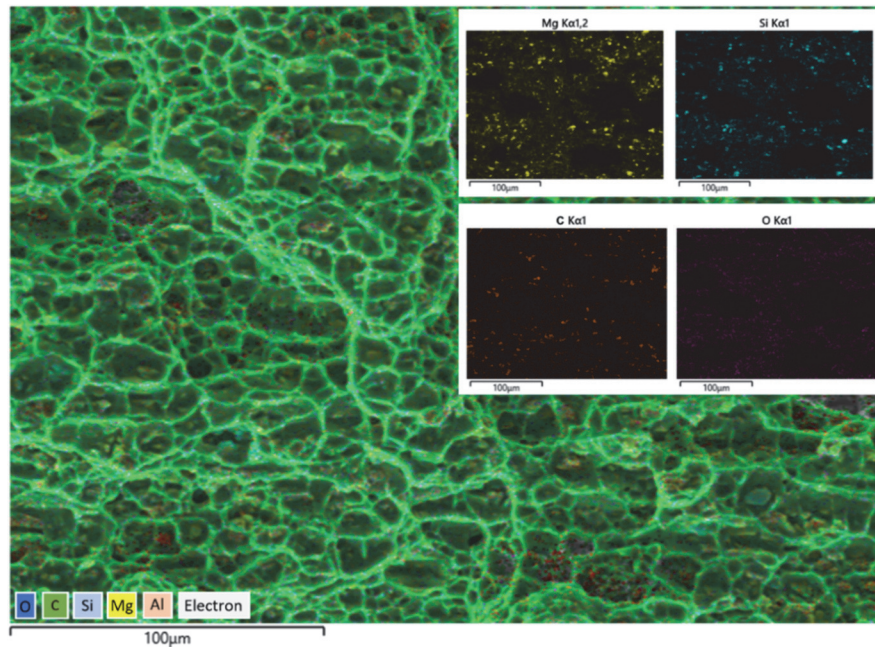

Figure 4: EDS Map showing the distribution of reinforced particles and elements in Al6061-3%graphite/6wt%SiC.

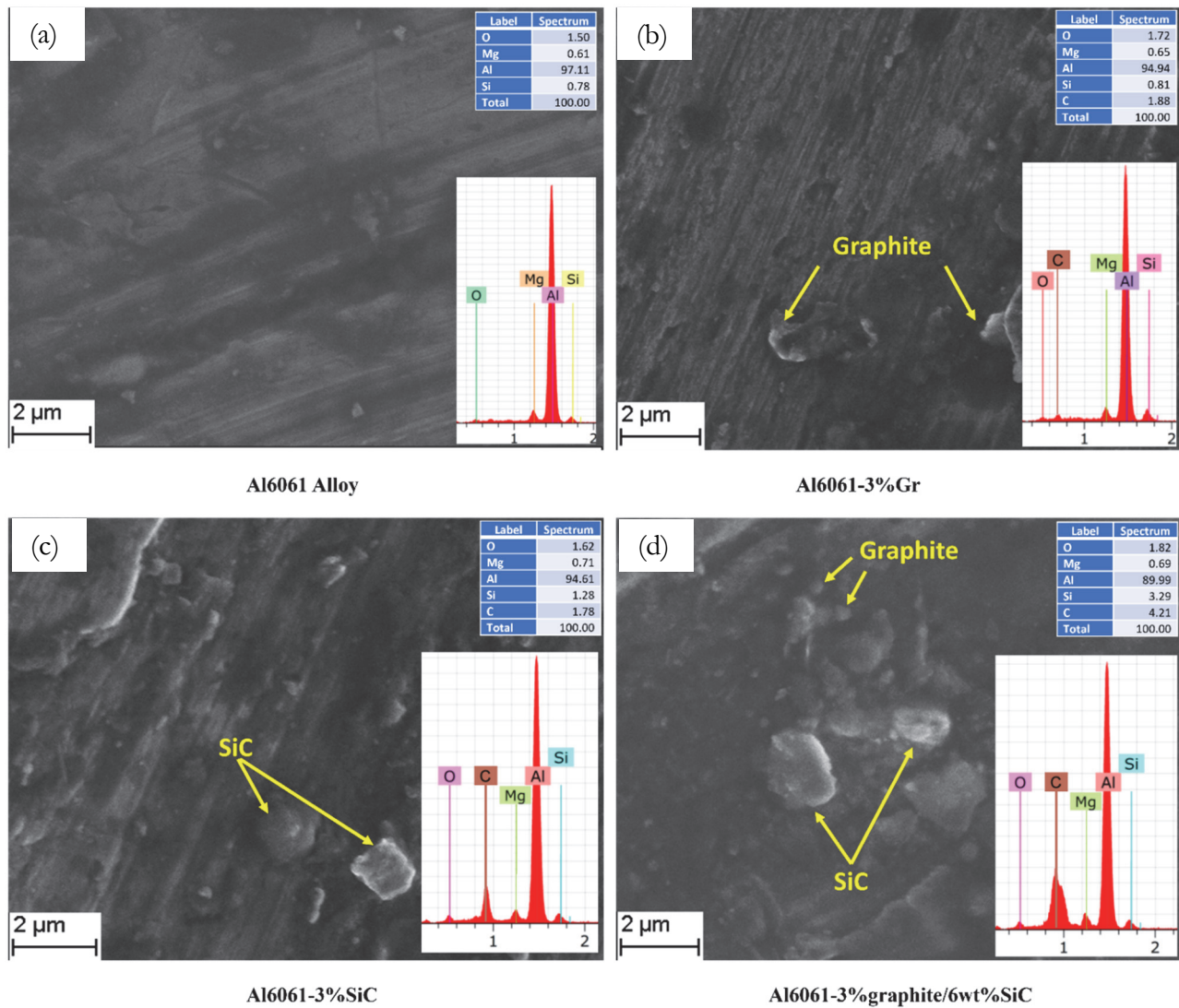

Figure 5: EDS profile analysis for the surfaces.

### Energy absorption

The impact testing experimentations are carried out for the prepared Charpy V notch specimens as per Taguchi's L9 design of experiments. The results of the investigations are listed in Tab. 3.

Case No	Wt% of Graphite	Wt% of SiC	Post-Ageing Cooling Methods	Material	Impact Energy Absorbed (J)
1	0	0	FC	Al6061 Alloy	49.8
2	0	3	AC	Al6061-3%SiC	42.8
3	0	6	WQ	Al6061-6%SiC	41.6
4	3	0	AC	Al6061-3%Gr	42.1
5	3	3	WQ	Al6061-3%Gr/3%SiC	39.2
6	3	6	FC	Al6061-3%Gr/6%SiC	50.7
7	6	0	WQ	Al6061-6%Gr	37.1
8	6	3	FC	Al6061-6%Gr/3%SiC	44.2
9	6	6	AC	Al6061-6%Gr/6%SiC	38.4

Table 3: Impact testing results of the L9 orthogonal array.



In Case 1, pure Al6061 alloy, furnace cooling significantly impacts energy absorption capacity of 49.8 J. The controlled and gradual cooling of furnace cooling seems to influence the material's energy absorption properties positively. This implies that the method's-controlled cooling process aids in forming a beneficial microstructure, improving the material's ability to absorb impact energy. The enhanced energy absorption capacity can be attributed to optimised structural arrangements and reduced internal stresses achieved through this cooling method.

Case 2, Al6061-3%SiC, undergoes air cooling (AC), resulting in an energy absorption capacity of 42.8 J. SiC reinforcements could introduce some brittleness, potentially affecting energy absorption. Case 3, Al6061-6%SiC, rapidly cooled through water quenching (WQ), yielding an energy absorption capacity of 41.6 J. The higher SiC content and rapid cooling could contribute to increased brittleness, affecting energy absorption.

Case 4, Al6061-3%Gr, undergoes air cooling (AC), resulting in an energy absorption capacity of 42.81 J. Graphite reinforcements could reduce the ductility, potentially affecting energy absorption. This reduction in energy absorption capacity due to graphite reinforcement aligns with the observed behaviour in Case 5, Al6061-3%Gr/3%SiC, where the combination of graphite and SiC reinforcements, coupled with rapid cooling, could contribute to the decrease in energy absorption capacity. Case 6, Al6061-3%Gr/6%SiC, is subjected to furnace cooling (FC), revealing a high energy absorption capacity of 50.7 J. Adding an extra 3% of silicon carbide (SiC) reinforcement to Al6061-3%Gr/3%SiC might decrease further ductility due to the potential brittleness associated with higher SiC content. However, the subsequent application of furnace cooling after ageing might increase energy absorption capacity. Furnace cooling involves a controlled and relatively slow cooling rate, enabling the formation of a refined microstructure with a well-defined grain size distribution. This microstructural refinement enhances the material's overall mechanical properties, including its toughness and ability to absorb impact energy.

Case 7, Al6061-6%Gr, with water quenching and case 9 - Al6061-6%Gr/6%SiC, with air cooling, nearly exhibit the same energy absorption capacity. The presence of 6% graphite/SiC reinforcement suggests an increased risk of brittleness due to the higher reinforcement content. Additionally, the excessive amount of reinforcements may cause accumulation, leading to a non-uniform distribution of the reinforcements and resulting in decreased mechanical properties. Water quenching's rapid cooling rate could amplify this brittleness, potentially reducing energy absorption capacity. The combined effect of 6% graphite and 6% SiC reinforcements and air cooling's intermediate cooling rate doesn't appear to influence the energy absorption capacity significantly. However, case 8 - Al6061-6%Gr/3%SiC with furnace cooling exhibits higher energy absorption capacity, i.e., 44.2 J.

The analysis of the presented cases underscores a significant observation: the energy absorption capacity of Al6061 and its composites, particularly those reinforced with graphite and/or SiC, is profoundly influenced by the post-ageing cooling method, with a particular emphasis on furnace cooling. Furnace cooling, characterised by its controlled and gradual cooling rate, consistently contributes to higher energy absorption capacities in various cases. This can be attributed to the method's ability to foster the development of an optimised microstructure, which, in turn, strengthens the materials' energy dissipation capability.

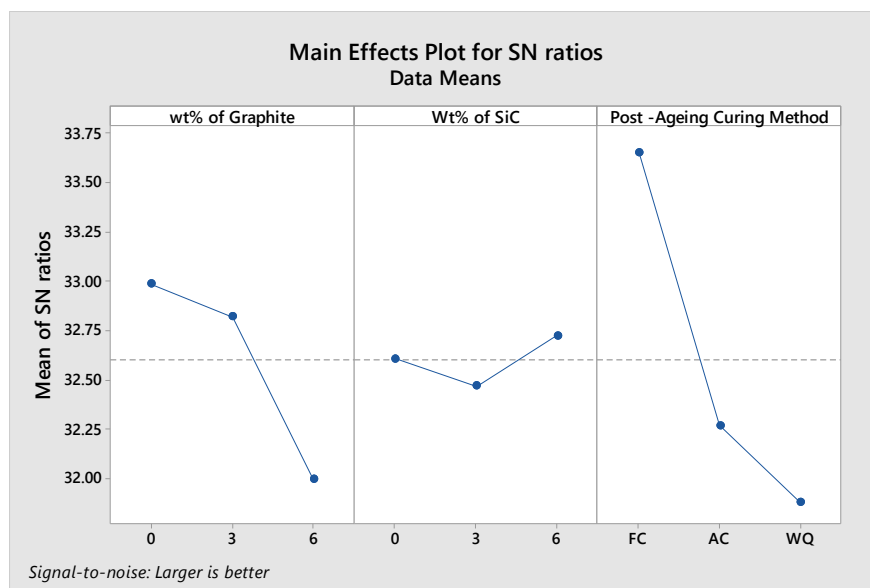

Figure 6: Effect of process parameters on energy absorption.

### Effect of process parameters

The impact of various parameters, including the weight percentage of graphite, the weight percentage of SiC, and Post-Aging cooling (PAC) methods, on the energy absorption of Al6061 and its composites was examined using Taguchi's DOE. The main effect plots for signal-to-noise ratios were depicted in Fig. 6, revealing that an increase in the weight percentage of graphite led to a reduction in energy absorption. Similarly, increasing the weight percentage of SiC in Al6061 resulted in a slight decrease in energy absorption.

When both graphite and SiC reinforcements are present in higher percentages, they can compromise the material's ductility, causing it to shift towards a more brittle behaviour. This, in turn, impacts the material's capacity to absorb impact energy and accounts for the observed trends in energy absorption.

Furthermore, furnace cooling yielded significantly higher energy absorption in both Al6061 and its composites compared to air-cooled and water-quenched samples. These results indicate the feasibility of determining optimal parameters to maximise energy absorption. Notably, the preference for furnace cooling arises from its controlled and gradual cooling rate, promoting a refined microstructure with well-defined grain sizes. This microstructural enhancement enhances the material's mechanical properties, particularly its toughness. This improved toughness enables effective absorption and dissipation of impact energy, resulting in the observed heightened energy absorption capacities. Hence, these findings highlight furnace cooling as a favoured method for optimising energy absorption performance in Al6061 and its composites.

Source	DF	Adj S.S.	Adj MS	F-Value	P-Value	Percentage Contribution
Wt% of Graphite	2	40.7	20.4	20.6	0.023	22.6
Wt% of SiC	2	3.4	1.7	1.7	0.41	01.9
PAC Methods	2	133.9	67.0	67.8	0.019	74.4
Error	2	2.0	1.0			01.1
Total	8	180.1				100.0

Table 4: Percentage of the contribution of process parameters on energy absorption.

ANOVA (Analysis of Variance) analysis, shown in Tab. 4, was conducted to determine each process parameter's contribution percentage, including the weight percentage of graphite, SiC, and post-ageing cooling methods, on the energy absorption of the Al6061 and composites. The obtained P-value for the post-ageing cooling method was 0.019, indicating a 95% or higher confidence level. The ANOVA analysis revealed that the PAC methods had the highest percentage of contribution (74.4%) on the energy absorption of the Al6061 and composites. This means how the samples were cooled after ageing significantly impacted their energy absorption properties.

Rapid cooling methods like water quenching introduced residual stresses and structural changes that could have hindered the materials' ability to absorb impact energy efficiently. In contrast, controlled cooling methods like furnace cooling enabled the development of a refined microstructure that enhanced mechanical properties, including toughness, directly affecting energy absorption.

On the other hand, the wt% of graphite (23%) and wt% of SiC had less than 2% contribution (Tab. 4). This implies that although these parameters had some influence on the energy absorption, their effect was relatively small compared to that of the PAC methods. Therefore, it can be concluded that the PAC method is the most critical parameter for achieving high energy absorption in the Al6061 and composites.

### Fractographic studies

Fractographic studies are beneficial for investigating the behaviour of materials under stress and identifying the causes of failure. In the case of Al6061 alloy and composites, fractographic studies helped to identify the brittle or ductile fractures, as shown in Fig. 7. From Fig.7, it can be determined that both brittle and ductile fractures occurred. The brittle fracture surfaces show clean and smooth surfaces with little deformation and small and isolated features known as dimples.

The microstructure of Al6061 and its composites also have micro-voids, a characteristic feature of ductile fracture. During plastic deformation, these micro-voids can form and grow, leading to the eventual fracture of the material. In contrast, brittle fractures typically do not involve significant plastic deformation and do not exhibit the formation of micro-voids. Also, deep dimples on the fracture surface indicate a ductile fracture. The dimples were caused by the stretching and elongation of the material during the fracture process. The presence of precipitates of Mg<sub>2</sub>Si inside the deep dimples is likely due to the ageing treatment at 460°C [14]. This treatment can cause the precipitation of Mg<sub>2</sub>Si particles, which can act as



nucleation sites for voids during the deformation process. These voids can coalesce and form deep dimples on the fracture surface. Mg<sub>2</sub>Si precipitates may contribute to the material's ductility by increasing the grain boundaries' strength and reducing the crack initiation and propagation likelihood.

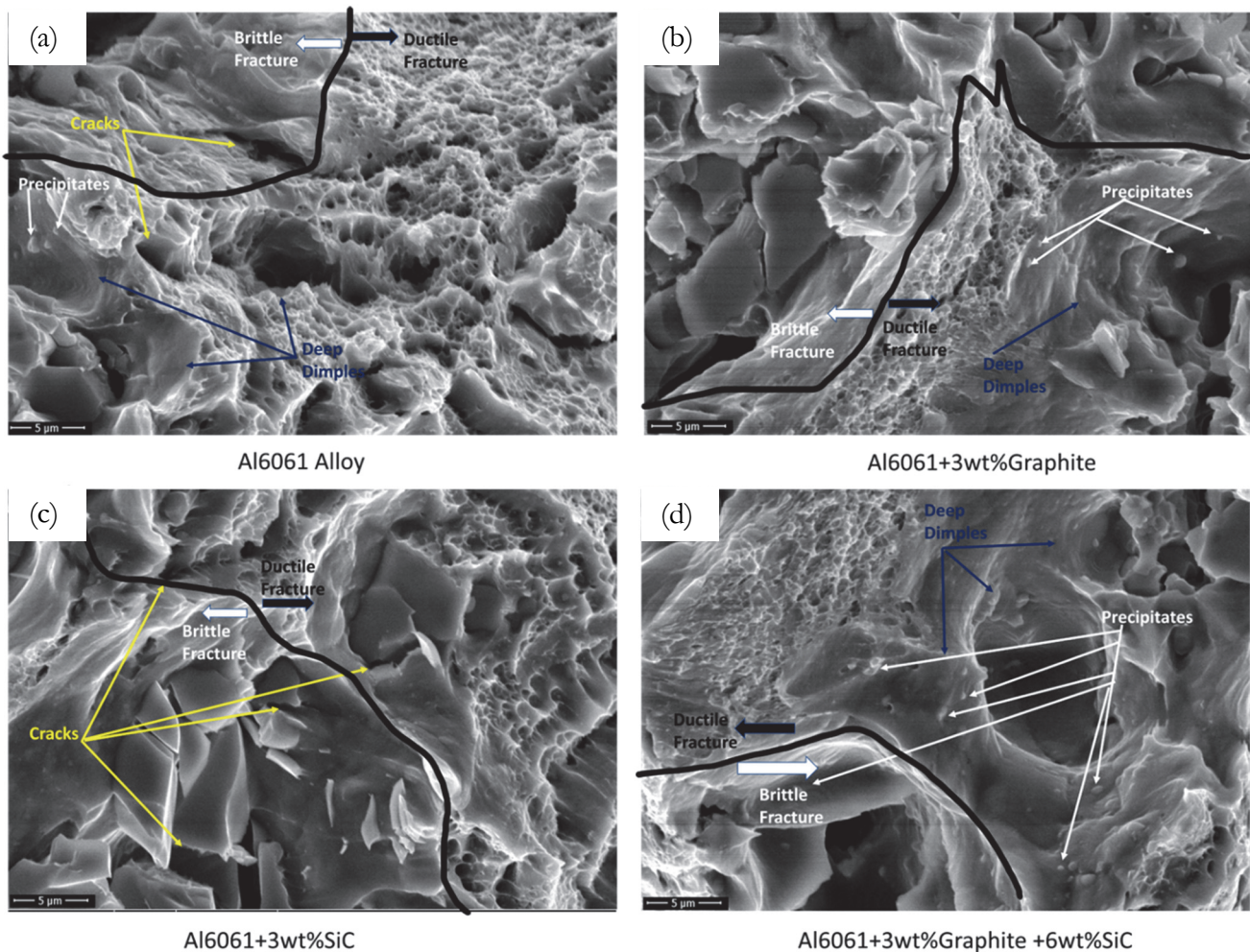

Figure 7: SEM images of fractured surfaces of Al6061 and its composites.

In the case of water quenching, the SEM images display distinct deep dimples, the presence of Mg<sub>2</sub>Si precipitates, the coalescence of micro-voids, and the occurrence of cracks. The rapid cooling rate associated with water quenching induces significant thermal stresses and thermal gradients within the material. Consequently, forming internal defects, such as micro-voids and cracks, becomes more likely. The deep dimples observed indicate localised plastic deformation and energy absorption during fracture.

On the other hand, furnace cooling involves a controlled cooling process within a furnace or similar environment. The SEM images of the fractured surfaces following furnace cooling typically exhibit fewer and shallower dimples compared to water quenching. The slower cooling rate associated with furnace cooling reduces thermal stresses and more uniform microstructural characteristics. Consequently, the failure mode becomes more controlled, with fewer prominent dimples observed. However, the presence of Mg<sub>2</sub>Si precipitates, micro-voids, and cracks still signifies failure, albeit with less pronounced plastic deformation.

In the case of air cooling, which involves natural cooling in ambient air without any specific cooling method, the SEM images of the fractured surfaces display a combination of features observed in both water quenching and furnace cooling. The cooling rate during air cooling is slower than water quenching but faster than furnace cooling. As a result, thermal stresses and defects can still arise, leading to dimples, Mg<sub>2</sub>Si precipitates, micro-voids, and cracks. This suggests a mixed failure mechanism involving localised plastic deformation and stress concentrations.

The presence of deep dimples, Mg<sub>2</sub>Si precipitates, and micro-voids on the fracture surface indicates ductile fracture and can contribute to the energy absorption capacity of the material. Dimples signify localised plastic deformation, while micro-



voids reveal the material's capability to absorb energy by deforming and absorbing impact forces. Mg<sub>2</sub>Si precipitates act as strengthening agents within the material's microstructure. Certain alloying elements form these fine particles when the material is exposed to elevated temperatures during precipitation hardening. These particles act as barriers to dislocation movement, making it more difficult for cracks to initiate and propagate through the material. Their presence essentially impedes the path of cracks, thereby enhancing the material's energy absorption capacity.

The material's microstructure is altered by the introduction of graphite and SiC particles, with the potential to enhance specific mechanical properties. However, the presence of these particles, particularly in higher concentrations or with non-uniform distribution, can result in stress concentrations around them. These regions can serve as sites for initiating cracks, thereby affecting the material's energy absorption capacity.

The fractographic studies show that the samples failed in a more ductile fracture, which indicates that the material was able to undergo significant deformation before failure. This suggests the material has good energy absorption capacity, as it can absorb energy by undergoing plastic deformation before fracturing.

## CONCLUSIONS

This study's objective was to comprehensively investigate the interplay between material composition and cooling methodologies on the impact energy absorption capabilities of Al6061 and its composites. To achieve this, a systematic approach was employed, combining experimental techniques with analysis to delve into the effects of varying parameters. This research's findings contribute to the scientific community by providing valuable insights into the effect of cooling methods on the mechanical performance of Al6061 and its composites. The following key conclusions can be drawn:

- The results demonstrate that the cooling method after the ageing treatment significantly influences the impact energy absorption capacity of Al6061 and composites. The study demonstrates a significant energy absorption capacity enhancement in Al6061 and its composites with FC compared to AC and WQ, showing a remarkable 16% improvement over AC and 18% over WQ
- The addition of graphite/SiC in the composites had a negative impact on the absorption capacity. The introduction of 6wt% SiC triggers a reduction of 16%, while the incorporation of 6wt% graphite leads to a more significant 26% decline in energy absorption capacity. These observed outcomes stem from the rapid cooling (WQ) applied after the ageing treatment.
- The energy absorption capacity of Al6061-3%Gr/6%SiC is observed to be 13% higher than that of Al6061-6%Gr/3%SiC. This comparison implies that adding higher graphite content in the hybrid composite leads to a decrease in the energy absorption capacity.
- The microstructural analysis showed that the fracture surfaces of the composites were predominantly ductile, which is desirable for improved impact energy absorption.

In future investigations, it is recommended to delve deeper into the influence of furnace cooling on Al6061 and its composite materials. While this study has already shed light on the significance of post-ageing cooling methods, particularly furnace cooling, further research could provide a more comprehensive understanding of the underlying mechanisms.

## FUNDING

This research received no specific grant from any funding agency in the public, commercial, or not-for-profit sectors.

## CONFLICT OF INTEREST

The authors declare that they have no conflict of interest.



## REFERENCES

- [1] Raviraj, M.S., Sharanaprabhu, C.M., Mohankumar, G.C. (2016). Experimental investigation of effect of specimen thickness on fracture toughness of Al-TiC composites, *Frat. Ed Integrita Strutt.*, 10(37), pp. 360–368, DOI: 10.3221/IGF-ESIS.37.47.
- [2] Sihame Ait Yahia, Lemya Hanifi Hachemi Amar, Z.B. and A.T. (2018). Effect of homogenisation models on stress analysis of functionally graded plates, *Struct. Eng. Mech.*, 67(5), pp. 527–544, DOI: 10.12989/sem.2018.67.5.527.
- [3] Mehala, T., Belabed, Z., Tounsi, A., Beg, O.A. (2018). Investigation of influence of homogenisation models on stability and dynamic of FGM plates on elastic foundations, *Geomech. Eng.*, 16(3), pp. 257–271, DOI: 10.12989/sem.2018.67.5.527.
- [4] Kenanda, M. A., Hammadi, F., Belabed, Z., Meliani, M. (2023). Free vibration analysis of porous functionally graded plates using a novel Quasi-3D hyperbolic high order shear deformation theory, *Frat. Ed Integrità Strutt.*, 64, pp. 266–282, DOI: 10.3221/IGF-ESIS.64.18.
- [5] Doddamani, S., Kaleemulla, M.K. (2019). Effect of Aging on Fracture Toughness of Al6061-Graphite Particulate Composites, *Mech. Adv. Compos. Struct.*, 6, pp. 139–146, DOI: 10.22075/MACS.2019.15614.1177.
- [6] Hua-Ping Tang, Qu-Dong Wang, Chuan Lei, Bing Ye, Kui Wang, Hai-Yan Jiang, Wen-Jiang Ding, Xiang-Feng Zhang, Zhen Lin, J.-B.Z. (2019). Effect of cooling rate on microstructure and mechanical properties of an Al-5.0Mg-3.0Zn-1.0Cu cast alloy, *J. Alloys Compd.*, 801, pp. 596–608, DOI: 10.1016/j.jallcom.2019.06.002.
- [7] B. Benjunior, A.H. Ahmad, Maarof Mohd. Rashidi, M.S.R. (2017). Effect of Different Cooling Rates Condition on Thermal Profile and Microstructure of Aluminium 6061, *Procedia Eng.*, 184, pp. 298–305, DOI: 10.1016/j.proeng.2017.04.098.
- [8] Saheed Akande, Oyinkan E. Ajaiyeoba, Temitayo M. Azeez, Omolayo M. Ikumapayi, Stephen A. Akinlabi, E.T.A. (2022). Investigating the precipitation hardening of 2024 aluminium alloy under different quenching media, *Mater. Today Proc.*, 62(6), pp. 4271–4274, DOI: 10.1016/j.matpr.2022.04.775.
- [9] Deore, H.A., Mishra, J., Rao, A.G., Mehtani, H., Hiwarkar, V.D. (2019). Effect of filler material and post process ageing treatment on microstructure, mechanical properties and wear behaviour of friction stir processed AA 7075 surface composites, *Surf. Coat. Technol.*, 374, pp. 52–64, DOI: 10.1016/j.surfcoat.2019.05.048.
- [10] Venkateswarulu, D., Cheepu, M., Krishnaja, D. (2018). Influence of Water Cooling and Post-Weld Ageing on Mechanical and Microstructural Properties of the Friction-Stir Welded 6061 Aluminium Alloy Joints, 877, pp. 163–176, DOI: 10.4028/www.scientific.net/AMM.877.163.
- [11] Deore, H.A., Bhardwaj, A., Rao, A.G., Mishra, J., Hiwarkar, V.D. (2020). Consequence of reinforced SiC particles and post process artificial ageing on microstructure and mechanical properties of friction stir processed AA7075, 16.
- [12] Yu-xun Zhang, You-ping Yi, Shi-quan Huang, F.D. (2016). Influence of quenching cooling rate on residual stress and tensile properties of 2A14 aluminum alloy forgings, *Mater. Sci. Eng. A*, 674, pp. 658–665, DOI: 10.1016/j.msea.2016.08.017.
- [13] G.P. Dolan, J.S.R. (2004). Residual stress reduction in 7175-T73, 6061-T6 and 2017A-T4 aluminium alloys using quench factor analysis, *J. Mater. Process. Technol.*, 153–154, pp. 346–351, DOI: 10.1016/j.jmatprotec.2004.04.065.
- [14] Şahbaz, M. (2021). Effect of Artificial Aging and Cooling Rate on Microstructure and Mechanical Properties of AA6082. 1st International Conference on Applied Engineering and Natural Sciences ICAENS 2021, 28, *European Journal of Science and Technology*, pp. 300–305.
- [15] Shengdan Liu, Jianghai You, Xinming Zhang, Yunlai Deng, Y.Y. (2010). Influence of cooling rate after homogenisation on the flow behavior of aluminum alloy 7050 under hot compression, *Mater. Sci. Eng. A*, 527(4–5), pp. 1200–1005, DOI: 10.1016/j.msea.2009.10.055.
- [16] Xu Z, Wang S, Wang H, Song H, Li S, C.X. (2020). Effect of Cooling Rate on Microstructure and Properties of Twin-Roll Casting 6061 Aluminum Alloy Sheet, *Metals (Basel)*, 10(9), pp. 1168, DOI: 10.3390/met10091168.
- [17] Hammar Ilham Akbar, Eko Surojo, Dody Ariawan, A.R.P. (2020). Experimental study of quenching agents on Al6061–Al<sub>2</sub>O<sub>3</sub> composite: Effects of quenching treatment to microstructure and hardness characteristics, *Results Eng.*, 6(100105), DOI: 10.1016/j.rineng.2020.100105.
- [18] Yasmin Begum, Bharath K N, Saleemsab Doddamani, Rajesh A M, M.K.K. (2020). Optimisation of process parameters of fracture toughness using simulation technique considering aluminum-graphite composites, *Trans. Indian Inst. Met.*, 73(12), pp. 3095 – 3103, DOI: 10.1007/s12666-020-02113-5.
- [19] Ashoka, E., Sharanaprabhu, C. M. and Krishnaraja, G.K. (2022). Effect of cenosphere and specimen crack lengths on the fracture toughness of Al6061-SiC composites, *Frat. Ed Integrità Strutt.*, 16(61), pp. 473–486,



- DOI: 10.3221/IGF-ESIS.61.31.
- [20] Mohamed Kaleemulla K, Rajesh A M, Saleemsab Doddamani, B.K.N. (2019). Generation of mechanically mixed layer during wear in hybrid aluminum MMC under as - cast and age hardened conditions, *SN Appl. Sci.*, 1(860), DOI: 10.1007/s42452-019-0906-5.
- [21] Doddamani, S., Kaleemulla, M. (2017). Experimental investigation on fracture toughness of Al6061–graphite by using Circumferential Notched Tensile Specimens, *Frat. Ed Integrità Strutt.*, 11(39), pp. 274–281, DOI: 10.3221/IGF-ESIS.39.25.
- [22] Suchendra, K. R., Sreenivasa, R. M. . and Ravikumar, M. (2022). A Study on microstructure, mechanical and fracture behavior of Al<sub>2</sub>O<sub>3</sub> - MoS<sub>2</sub> reinforced Al6061 hybrid composite, *Frat. Ed Integrità Strutt.*, 16(61), pp. 244–253, DOI: 10.3221/IGF-ESIS.61.16.
- [23] ASTM E23-18. (2023). Standard Test Methods for Notched Bar Impact Testing of Metallic Materials, .
- [24] Tioua, T., Djeghader, D. and Redjel, B. (2022). The Mechanical properties and statistical analysis of the Charpy impact test using the Weibull distribution in jute-polyester and glass-polyester composites, *Frat. Ed Integrità Strutt.*, 16(62), pp. 326–335, DOI: 10.3221/IGF-ESIS.62.23.